

Specifications

Model Number: 10-0114
Input Voltage: 230v AC
Frequency: 45 - 65 Hz.
Lamp Type: See Chart on Next Page
Designed For: One or Two Lamps (max. 70 W per lamp)
Certifications: CE / RoHS
Size: 9.76" x 2.6" x 2.1" (248 x 66 x 53 mm)
Weight: 1 lb. 7 oz. (0.65 kg.)
Mounting: Slotted Mounting Tabs
Special Features: LED's Showing Lamp Operation

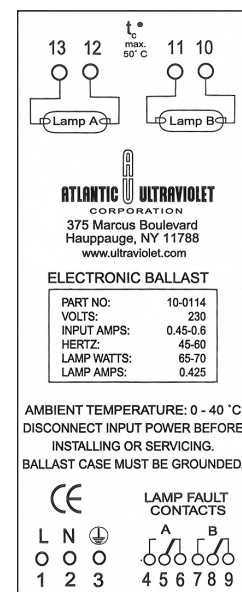

The information and recommendations contained in this publication are based upon data collected by the Atlantic Ultraviolet Corporation® and are believed to be correct. However, no guarantee or warranty of any kind, expressed or implied, is made with respect to the information contained herein. Specifications and information are subject to change without notice.

Lamp Types

One or Two (Identical Pairs)

Low Ozone Instant Start	Ozone Producing Instant Start
G24T5L	G24T5VH
G24T5L/U	G24T5VH/U
G30T5L	G30T5VH
G30T5L/U	G30T5VH/U
G36T5L	G36T5VH
G36T5L/U	G36T5VH/U
G48T5L	G48T5VH
G48T5L/U	G48T5VH/U
G64T5L	G64T5VH

This ballast may be acceptable for use with lamps not listed here.
 Contact us to discuss your requirement.

Connections

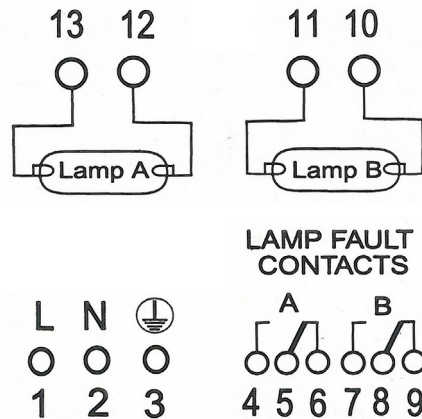

The information and recommendations contained in this publication are based upon data collected by the Atlantic Ultraviolet Corporation® and are believed to be correct. However, no guarantee or warranty of any kind, expressed or implied, is made with respect to the information contained herein. Specifications and information are subject to change without notice.