

Specifications

Model Number: 10-0514A
Input Voltage: 230 VAC
Frequency: 50/60 Hz.
Designed for: BioLogic® Water Purifiers
 Model BIO-1.5 and BIO-3.0
Certifications: CE
Size: 4.92" x 2.4" x 1.38" (125 x 60 x 35 mm)
Weight: 10 oz. (0.3 kg)
Mounting: Slotted Mounting Tabs
Special Features: Green & Red LED, Buzzer if lamp not working.



WARNING: The equipment that this ballast is used with requires connection to a known good ground. It is the User's responsibility to insure that their equipment is properly grounded in compliance with the National Electrical Code and any applicable local codes. Equipment wiring and hook up should be performed by a qualified, licensed electrician. Failure to comply with this requirement could result in serious injury or death.

Grounding Kits are available. Please contact the factory with any questions.



10-0514A **CE**

Electronic Ballast for T5L/4 lamps

Lamps GPH212 thru GPH843

INPUT VOLTAGE	INPUT CURRENT	LAMP POWER	LAMP CURRENT
230vac 50/60Hz	0.06A-0.2 A	10-40W	425mA Approx.

Green and Red LED Indicate Status.
 Alarm Sounds if the Lamp is Not Working.

info@ultraviolet.com
 631.273.0500 • ultraviolet.com

ATLANTIC ULTRAVIOLET
CORPORATION®
Hauppauge, NY • USA

The information and recommendations contained in this publication are based upon data collected by the Atlantic Ultraviolet Corporation® and are believed to be correct. However, no guarantee or warranty of any kind, expressed or implied, is made with respect to the information contained herein. Specifications and information are subject to change without notice.

Connections

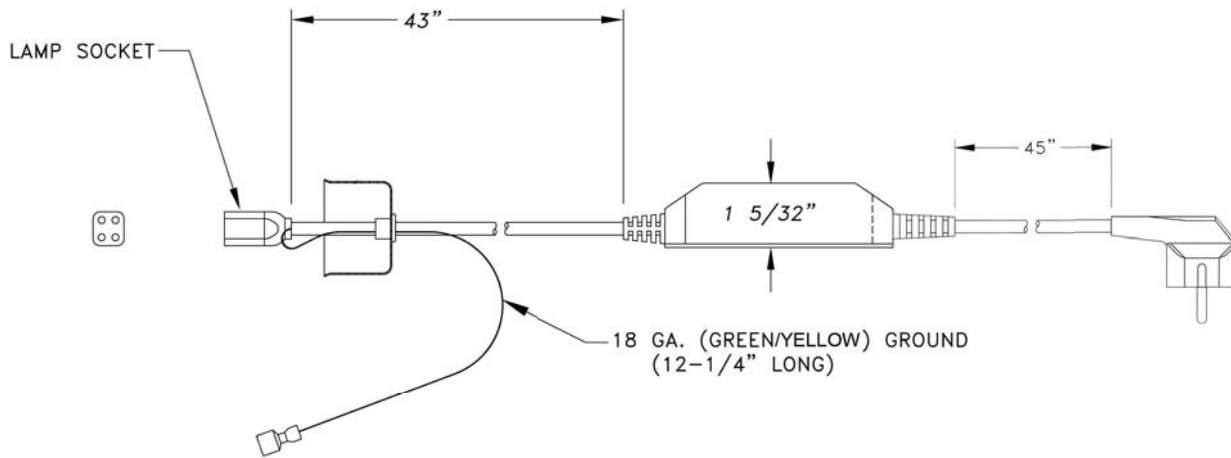

The information and recommendations contained in this publication are based upon data collected by the Atlantic Ultraviolet Corporation® and are believed to be correct. However, no guarantee or warranty of any kind, expressed or implied, is made with respect to the information contained herein. Specifications and information are subject to change without notice.