

10-1109 – Trojan Equivalent Replacement Electronic Ballast

Specifications

Model Number:	10-1109 Equivalent Replacement Ballast for Trojan Technologies Part #903988-001
Input Voltage:	198–264v AC
Frequency:	50/60 Hz.
Efficiency:	>90%
Operating Frequency:	25–60K Hz.
Power Factor:	>0.9 typ.
Ambient Temperature:	0–40° C
Tc Temperature:	Max. 70° C
Dimensions:	18" x 5.5" x 1.65"
Weight:	2.2 lbs.
Use with:	Trojan's UV 3000 Plus system

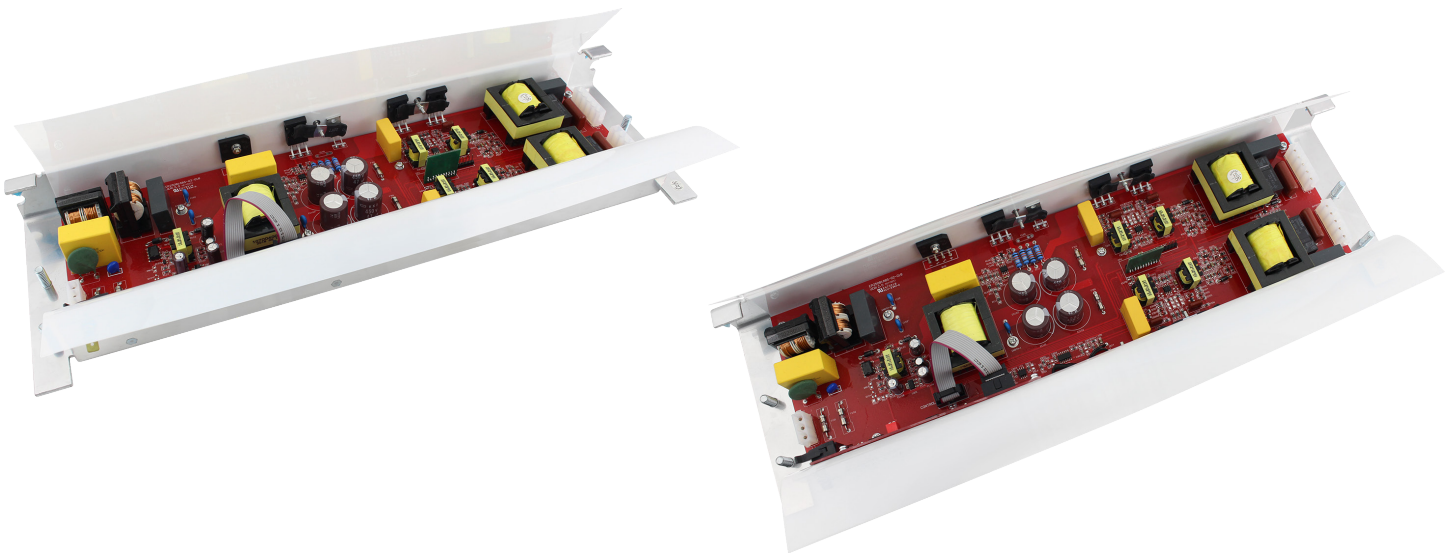

The information and recommendations contained in this publication are based upon data collected by the Atlantic Ultraviolet Corporation® and are believed to be correct. However, no guarantee or warranty of any kind, expressed or implied, is made with respect to the information contained herein. Specifications and information are subject to change without notice.

Features

- Electronic ballast for two-lamp operation
- Preheat start
- Status forwarding / PWM signal feedback

Mounting Restrictions

- For use with Trojan UV 3000 Plus System
- Disconnect input power before installing or servicing
- Ballast case must be grounded
- For indoor use only
- Do not short any two wires of the input and output wires
- Max. cable length between ballast and lamp: 16.4 ft

Wiring Diagram

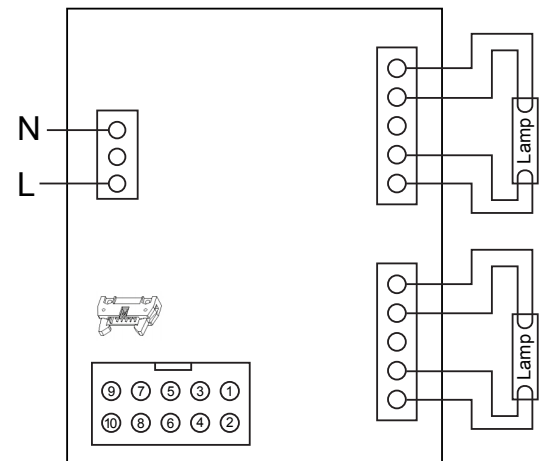
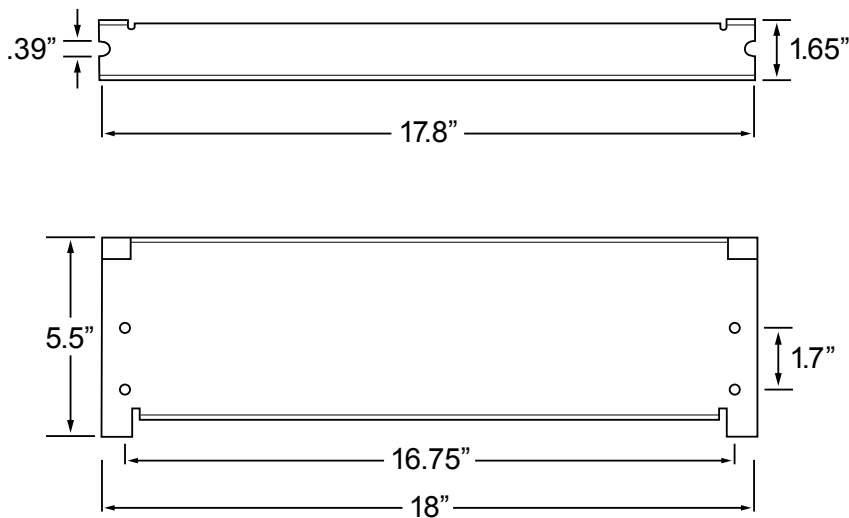

The information and recommendations contained in this publication are based upon data collected by the Atlantic Ultraviolet Corporation® and are believed to be correct. However, no guarantee or warranty of any kind, expressed or implied, is made with respect to the information contained herein. Specifications and information are subject to change without notice.